



WATER



GAS



ENVIRONMENT



PEST CONTROL

INTRODUCING...

# HYGENIKX+

The ultimate air and surface hygiene amplifier

PROVEN TO REDUCE FOOD SPOILAGE

REDUCE FOOD WASTE & COST

IMPROVE HOSPITALITY HYGIENE AND SAFETY

KILLS SALMONELLA, E.COLI, NOROVIRUS and other primary sources of infections

TARGET & ELIMINATE HARMFUL BACTERIA



HyGenikx is an advanced and compact, wall mounted hygiene amplification system, proven to eradicate bacteria and viruses throughout the food service & hospitality environment, washrooms, changing rooms and beyond, in terms of applications.

Utilising a combination of the most effective air and surface sterilisation technologies available, HyGenikx provides round-the-clock hygiene and safety protection, controls odours and has also significantly been proven to prolong the life of fresh perishable foods.



WATER



GAS



ENVIRONMENT



PEST CONTROL

## THE ULTIMATE AIR & SURFACE HYGIENE AMPLIFIER

## HYGENIKX+

### The HyGenikx range features and benefits:

- Kills *Escherichia coli* (*E. coli*), *Staphylococcus aureus* (*S. aureus*), *Clostridium difficile* (*C. difficile*), *Aspergillus fumigatus*, and other primary sources of infections
- Significantly improves hygiene standards to levels impossible to maintain with traditional cleaning methods alone
- Eliminates bacteria, viruses, moulds, fungi and volatile organic compounds (VOCs), both in the air and on exposed surfaces, even in the hardest to reach places
- Safe to use and for the environment
- Eradicates unpleasant odours by tackling them at source
- Proven to deplete harmful *Listeria monocytogenes* and *Listeria innocua* from surfaces to undetectable levels
- Improves infection control for staff and customers
- Proven to reduce spoilage by extending the shelf-life of perishable food on average by 58%, and up to 150% for certain produce\*\*
- Low energy consumption, only 85 watt
- Easy to change lamp and backup battery, requires no onsite engineer
- Power via a plug that allows flexible installation and easy connection to existing sockets or to switched spurs
- Available in white or titanium finish
- Models to suit various applications, including front of house, washrooms, food prep areas, cold rooms, refuse areas and beyond (see model reference chart)

\*\*Validation of a HyGenikx air purification unit as an aid to prolong the shelf-life of refrigerated fresh foodstuff and to improve environmental conditions. ALS Life Sciences Europe

### MODEL REFERENCE CHART

	GENERAL*		FOOD*†		REFUSE*	
	WHITE finish	TITANIUM finish	WHITE finish	TITANIUM finish	WHITE finish	TITANIUM finish
10m <sup>2</sup>	HGX-W-10-S	HGX-T-10-S	HGX-W-10-F	HGX-T-10-F	×	×
20m <sup>2</sup>	HGX-W-20-S	HGX-T-20-S	HGX-W-20-F	HGX-T-20-F	×	×
30m <sup>2</sup>	HGX-W-30-S	HGX-T-30-S	HGX-W-30-F	HGX-T-30-F	×	×
NON-OCCUPIED	×	×	×	×	HGX-W-15-R	HGX-T-15-R

\*GENERAL: for use in areas such as washrooms, front of house and changing areas / FOOD: for use in areas such as cold rooms and food prep areas / REFUSE: NOT for use in areas of continuous occupation.

†FOOD area models are supplied with food safe shatterproof lamps.

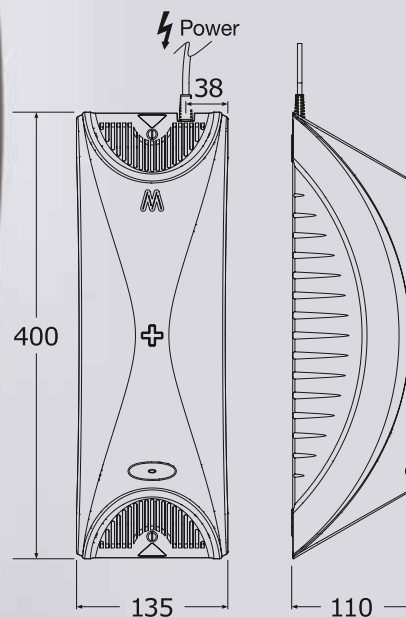

### SPECIFICATION

- Combines technologies: Germicidal Oxidation, Germicidal Irradiation, Dual waveband Plasma Quattro.
- Services: 240/50/1. Uninterrupted supply – 24 hour operation required. High level.
- Dimensions: 400 x 135 x 110mm
- EC declaration of conformity
- CE mark
- Low voltage directive 2014/35/EU
- EN 60335-1:2012 +A13:2017
- EN 60335-2-59:2003 +A1:2006 +A2:2009
- EN 62233:2008
- Class 1 certified for electrical insulation
- Designed and manufactured to EUOTA (European Ozone Trade Association) requirements



WATER



GAS



ENVIRONMENT



PEST CONTROL

## THE ULTIMATE AIR & SURFACE HYGIENE AMPLIFIER

## HYGENIKX+

### WHITE finish



Model	Description
HGX-W-10-S	WHITE / 10m <sup>2</sup> GENERAL* areas / lamp type <b>YELLOW</b>
HGX-W-20-S	WHITE / 20m <sup>2</sup> GENERAL* areas / lamp type <b>GREEN</b>
HGX-W-30-S	WHITE / 30m <sup>2</sup> GENERAL* areas / lamp type <b>RED</b>
HGX-W-10-F	WHITE / 10m <sup>2</sup> FOOD*† areas / lamp type <b>ORANGE</b>
HGX-W-20-F	WHITE / 20m <sup>2</sup> FOOD*† areas / lamp type <b>BLUE</b>
HGX-W-30-F	WHITE / 30m <sup>2</sup> FOOD*† areas / lamp type <b>PURPLE</b>
HGX-W-15-R	WHITE / REFUSE* areas / lamp type <b>GREY</b>

### TITANIUM finish



Model	Description
HGX-T-10-S	TITANIUM / 10m <sup>2</sup> GENERAL* areas / lamp type <b>YELLOW</b>
HGX-T-20-S	TITANIUM / 20m <sup>2</sup> GENERAL* areas / lamp type <b>GREEN</b>
HGX-T-30-S	TITANIUM / 30m <sup>2</sup> GENERAL* areas / lamp type <b>RED</b>
HGX-T-10-F	TITANIUM / 10m <sup>2</sup> FOOD*† areas / lamp type <b>ORANGE</b>
HGX-T-20-F	TITANIUM / 20m <sup>2</sup> FOOD*† areas / lamp type <b>BLUE</b>
HGX-T-30-F	TITANIUM / 30m <sup>2</sup> FOOD*† areas / lamp type <b>PURPLE</b>
HGX-T-15-R	TITANIUM / REFUSE* areas / lamp type <b>GREY</b>

### Replacement LAMP & BATTERY kits

- Lamps must be replaced every year to ensure optimum performance of the system.
- FOOD\*† area models are supplied with food safe lamps which have a shatterproof protective sheath around the lamp.
- Replacement kits include a backup battery which needs to be fitted with the lamp.



HGX-20-S



HGX-20-F

Model	Description
HGX-10-S	Includes replacement LAMP (type <b>YELLOW</b> ) and backup BATTERY for use in 10m <sup>2</sup> GENERAL* areas
HGX-20-S	Includes replacement LAMP (type <b>GREEN</b> ) and backup BATTERY for use in 20m <sup>2</sup> GENERAL* areas
HGX-30-S	Includes replacement LAMP (type <b>RED</b> ) and backup BATTERY for use in 30m <sup>2</sup> GENERAL* areas
HGX-10-F	Includes replacement food safe shatterproof LAMP (type <b>ORANGE</b> ) and backup BATTERY for use in 10m <sup>2</sup> FOOD*† areas
HGX-20-F	Includes replacement food safe shatterproof LAMP (type <b>BLUE</b> ) and backup BATTERY for use in 20m <sup>2</sup> FOOD*† areas
HGX-30-F	Includes replacement food safe shatterproof LAMP (type <b>PURPLE</b> ) and backup BATTERY for use in 30m <sup>2</sup> FOOD*† areas
HGX-15-R	Includes replacement LAMP (type <b>GREY</b> ) and backup BATTERY for use in REFUSE* (non-occupied) areas

\*GENERAL: for use in areas such as washrooms, front of house and changing areas / FOOD: for use in areas such as cold rooms and food prep areas / REFUSE: NOT for use in areas of continuous occupation. †FOOD area models are supplied with food safe shatterproof lamps. The protective sheath is an integral part of the lamp and must not be removed.